



# MEP<sup>®</sup> Tray

Modular Extensive Planting System



 **043 - 002**  
Made from minimum  
50% recycled material

 **ecospecifier**  
2010/11  
as seen on [www.ecospecifier.org](http://www.ecospecifier.org)

Solutions for Sustainable Urban Development

# MEP® Tray

Research worldwide has shown that green roofs limit the impact of climate change, underlining the valuable role they play in sustainable design. They reduce heat transmission from rooftop to habitable space below, lower ambient temperature, mitigate urban heat island effect, reduce rainwater runoff, and improve air quality and aesthetics.

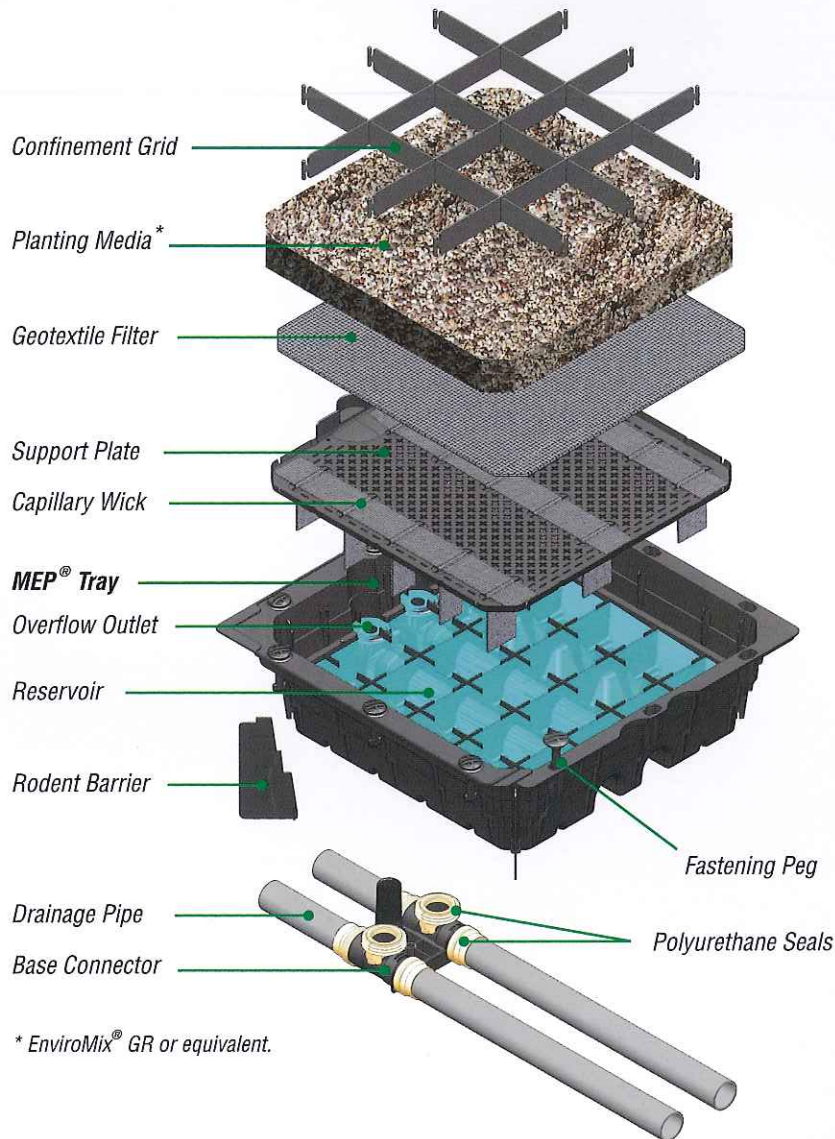

## What is MEP® Tray

The **Elmich MEP® Tray** (Modular Extensive Planting Tray) system allows quick realisation of extensive green roofs. It is a lightweight and robust planting tray with water storage compartments made from high-strength UV-stabilised polypropylene.

The system includes a support plate with anti-root overflow outlet covers, capillary wicks, geotextile filter, confinement grid, joining and fastening pegs, rodent barriers, base connector and drainage pipes.

The water reservoir in each **MEP® Tray** supports long term plant sustainability with minimal maintenance.

The modular tray design allows sustained plant growth and its light weight facilitates easy creation of desired designs and patterns. Each **MEP® Tray** including accessories, saturated planting media, plants and stored water weighs less than 30kg.

The self-contained **MEP® Tray** may be pre-planted in a nursery prior to installation to achieve instant greening of rooftops.

**MEP® Tray** components are manufactured primarily from recycled plastics, supporting all international Green Building certifications.

# DISTINCTIVE FEATURES

## Capillary Wicks

Capillary Wicks in the Support Plate convey water to the geotextile filter and planting media. This also discourages root incursion into the reservoir.

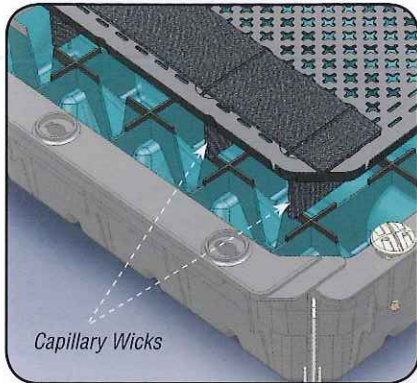

## Placement of Planting Media

The MEP® Tray has a fitted Support Plate for placement of a geotextile filter. Its small apertures stop excess planting media from getting into the reservoir.



## Erosion Control

A Confinement Grid minimises media spillage within the MEP® Tray. It is attached to the tray to prevent it from being dislodged.

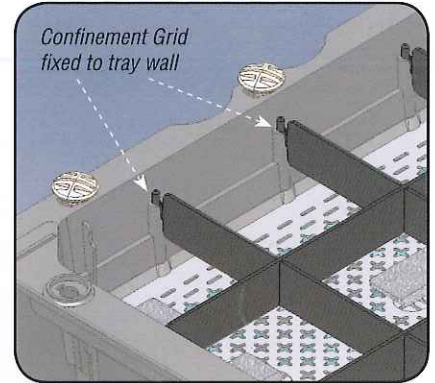

## Securing of Trays

Adjoining MEP® Trays are secured by fastening pegs. Each tray may be bolted to the substrate via the Base Connector for additional security if required.

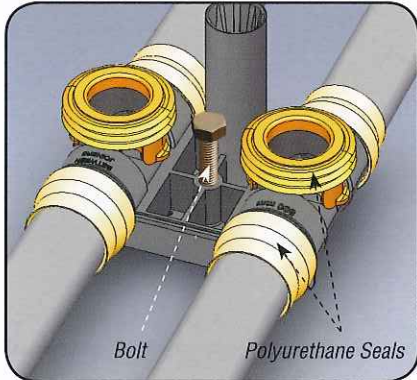

## Water Seepage

Ridges at the edge and around the fastening holes of the MEP® Tray prevent water seepage between adjoining trays keeping the roof beneath dry.

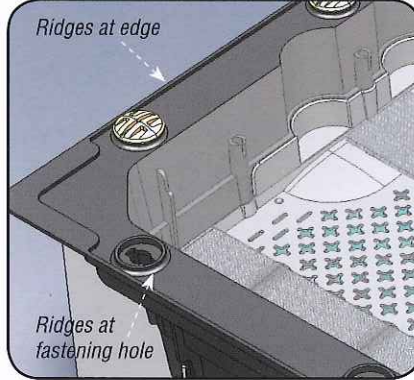

## Non-Intrusive Base

The MEP® Tray has a smooth base without any protrusions allowing it to be placed directly onto the waterproofing membrane without damaging it.

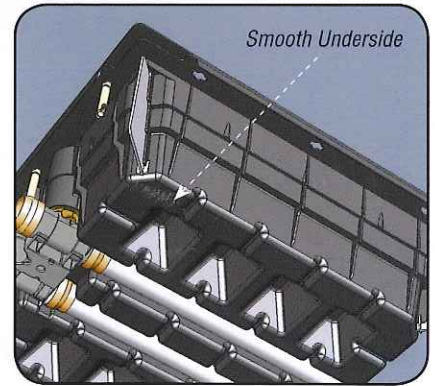

## Independent Drainage

The MEP® Tray utilises an independent drainage system pre-installed beneath the trays. Polyurethane seals used at the joints ensure watertightness.

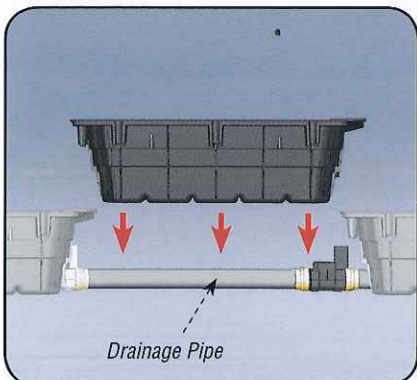

## Fast Installation & Removal

MEP® Tray units are placed onto a pre-installed drainage network. Trays are easily added or removed without affecting the drainage network.

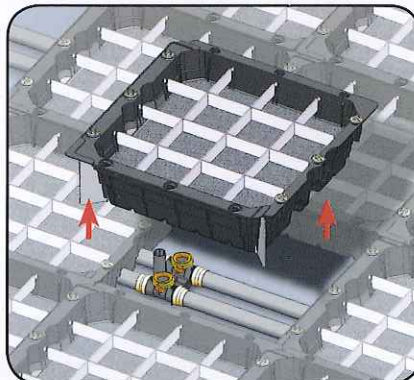

## Rodent Barriers

Rodent Barriers at each corner of the MEP® Tray prevent rodents infesting the space between trays and uplifting of trays by strong winds.

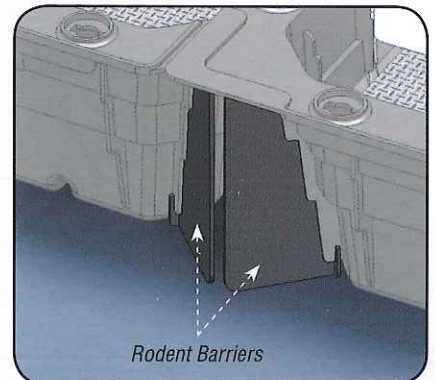

## Specifications

<b>Material</b>	Polypropylene
<b>Colour</b>	Black
<b>Dimensions</b>	
Overall	530 x 530 x 150mm
Nominal	500 x 500 x 150mm
<b>Design weight</b> (inclusive of plants)	120kg/m <sup>2</sup>
<b>Media depth</b>	
Nominal	65mm
Max	75mm
<b>Water storage</b>	7litres
<b>Tray + Accessories</b>	
Unfilled	2.5kg
With water & saturated media	26kg

## Advantages

- Established extensive green roof in short lead time
- Modular, lightweight and portable
- Pre-planting in nursery environment
- Fast installation
- Drainage system independent of trays
- Quick discharge of excess water
- Easy plug-in assembly to drainage system
- Tray replacements do not affect drainage system
- Watertight drainage pipe and connector joints
- Non-clogging of reservoir and drainage channels
- Effective rodent barrier
- Spill-proof placement of planting media
- Capillary wicks facilitate use of stored water
- Optional securing of trays to substrate
- Easily dismantled, stored offsite and re-assembled
- Made from recycled materials
- Supports Green Building certification



**Note:** The information provided in this brochure is based on current knowledge and experience and does not infer any legally binding assurance or warranty, expressed or implied. Intending purchasers should verify whether any changes to specifications or applications or otherwise have been made since the issue of this literature. Environmental-friendly recycled materials are used wherever possible and physical product properties including colour may differ due to source of raw materials used. Colour may also fade due to UV exposure. All components of the product are designed for specific application, design calculations and any variation and/or deviation therefrom shall be the responsibility of the Specifier and/or User.

Distributed by:



Singapore: +65 6356 2800

info@elmich.com

www.elmich.com



Strategic Partner of:

